

All rights reserved. This drawing is the property of Hunter Douglas Scandinavia AB. The drawing may not be copied or multiplied in any way, neither wholly nor in part. It may not be submitted for perusal, or in any way shared with third parties without the written consent of Hunter Douglas Scandinavia AB.

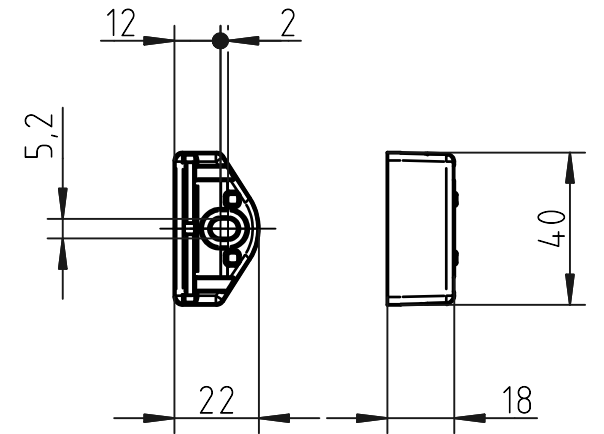

Snap-fit distance bracket (1 : 2)

Option A: (1 : 2)
Cassette bracket for 27mm offset
used with snap-fit distance brackets

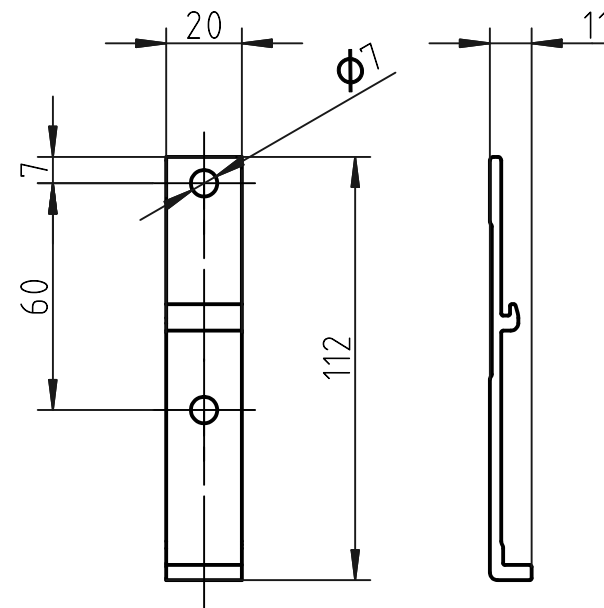
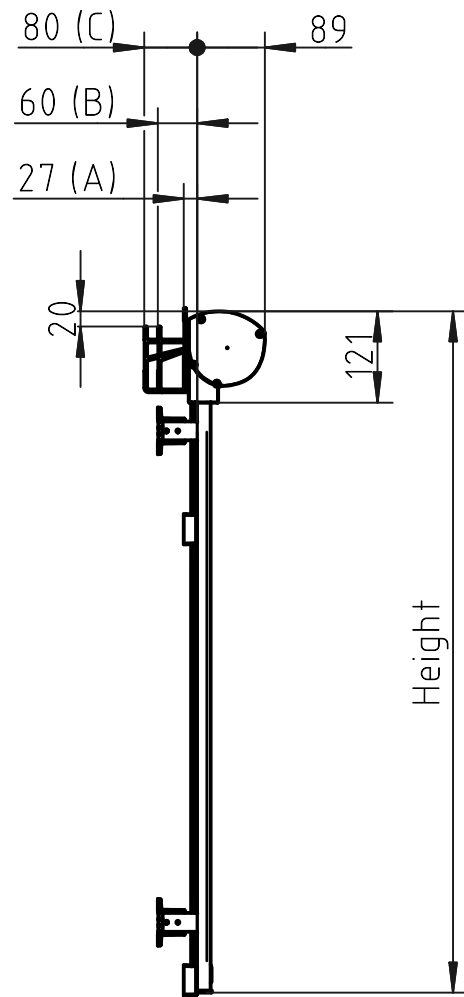
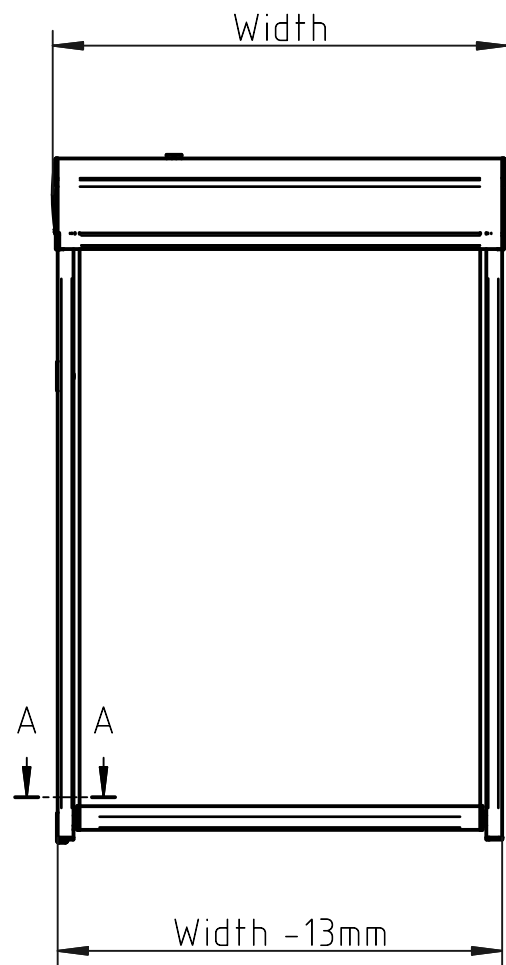
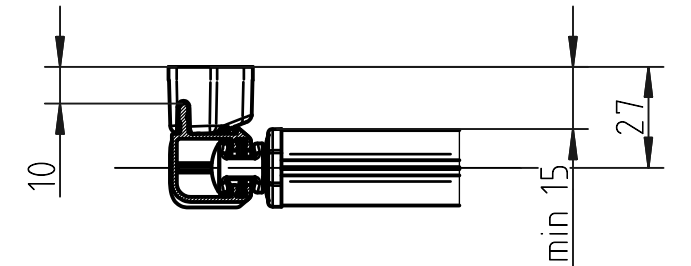

A-A (1 : 2)

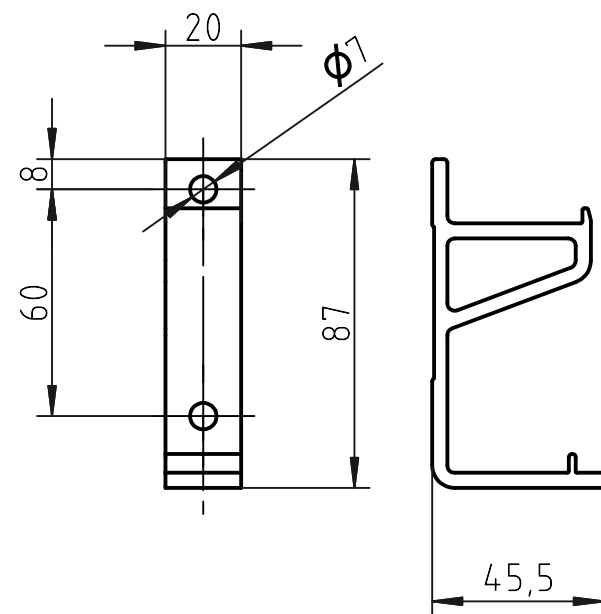

Option B:
Cassette bracket for 60mm offset,
and adjustable distance brackets

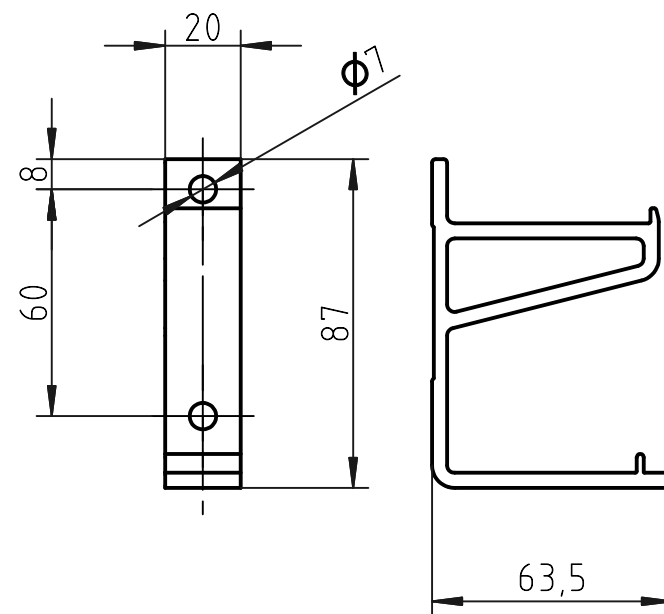

Option C: (1 : 2)
Cassette bracket for 80mm offset,
and adjustable distance brackets

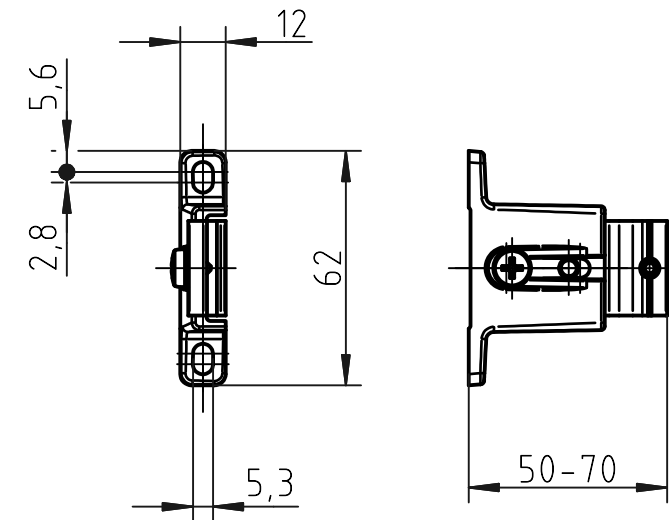

Adjustable distance bracket (1 : 2)
(Extension kit available.)

Designer CS	Drawn CS	Approved	Weight 0,0 kg		Date 2014-10-22	Replaces
HunterDouglas		Description Vertical screen awning			Scale 1:10	Sheet 1 / 1
Hunter Douglas Scandinavia AB		Article number VS62			Drawing number VS62	Rev. 1